

The PRO-LT is designed for use on commercial doors with standard lift tracks that require no more than 15 cycles per hour

STANDARD FEATURES

- 2 year Warranty
- **Control Circuit (2 options)**
- * **1- (M)** Heavy duty relays incorporating the new UL325 (2010) Interface Module.
 - *C2 factory wiring standard (constant pressure close), B2 wiring can be field set by moving 1 jumper and installing Micanan monitored fail safe photo-eyes (supplied) or (optional) Micanan compatible monitored fail safe electric edge
- 2-** Heavy duty relays (Not available in US or other areas where UL325 (2010) is mandated)
 - *C2 factory wiring standard (constant pressure close), B2 wiring can be field set by moving 1 jumper. Provisions for standard reversing devices.
- 24V class 2 control circuit with 40VA transformer to protect against short circuit
- External radio control terminal strip
- Low friction powder metal limit cam nuts with fully adjustable rotary type limit switch assembly
- Three button open-close-stop control station Nema-1
- 1/2 HP high starting torque, instant reversible motor protected by internal automatic thermal overload device
- Motor removable without affecting limit settings
- Heavy duty 4L V-belt
- #41 roller chain & sprockets on all internal drives
- Adjustable friction clutch
- 3/4" permanently lubricated & sealed ball bearings on pulley shaft
- 1" permanently lubricated & sealed ball bearings on final drive shaft
- Solenoid brake available (optional PRO-LTB)
- Emergency quick release disconnect for manual operation
- #48 roller chain drive on trolley rail assembly
- Trolley track for doors up to 12' standard
- Door speed 9" per second
- Baked on dark grey coat finish
- Shipping weight 60 lbs (excludes rails)
- For use on doors up to 16' high



Commercial limited duty belt drive trolley operator

When ordering a PRO-LT operator, supply Micanan with the following information

- Door height
- Door width
- Voltage/Phase
- Safety devices
- Options

MECHANICAL DIMENSIONS

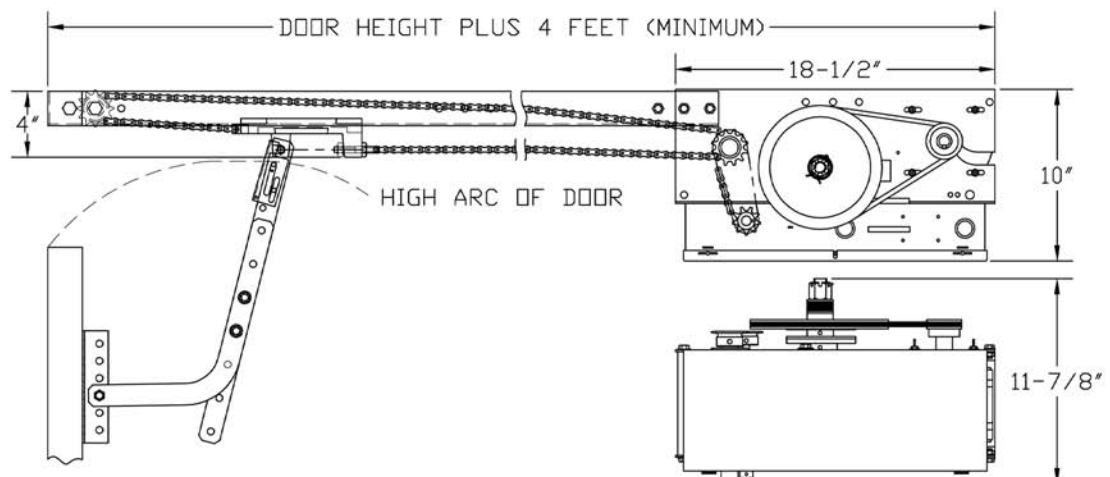

FOR MORE INFORMATION, PLEASE VISIT WWW.MICANAN.COM OR CONTACT US AT

MICANAN HEAD OFFICE: 1380 St-Regis Blvd. Dorval, QC H9P 2T5 Canada | Tel: (514) 822-1116 | Toll-Free: 1-877-888-1116 | Fax: (514) 822-1118 | Toll-Free: 1-877-888-1118

MICANAN PHOENIX: 1236 W. Southern Ave. Suite 104 Tempe, Arizona USA 85282 | Tel: (480) 557-0070 | Toll-Free: 1-888-816-8584 | Fax: (480) 557-8488

MICANAN ATLANTA: 2885 N. Berkeley Lake Rd Suite 7 Duluth, Georgia USA 30096 | Tel: (678) 584-2543 | Toll-Free: 1-800-798-2543 | Fax: (678) 584-2544